

## 6600 Series

Off-Highway Series 6600

### RATINGS

Model		Gross Input Torque N•m (lb-ft)	Gross Input Power kW (hp)	Turbine Torque Net N•m (lb-ft)
H6620	Rear Dump Truck, Coal Hauler, Articulated Dump, Hauling Applications	3390 (2500)	567 (760)	5139 (3790)
M6620	General	3390 (2500)	567 (760)	5139 (3790)
	Oil Field	3729 (2750)	671 (900)	5423 (4000)
	Crash Truck (ARFF Vehicle)	4474 (3300)	764 (1025)	7050 (5200)
	Agricultural Tractor	2712 (2000)	522 (700)	4528 (3340)
S6620	Stationary Applications	3390 (2500)	567 (760)	5139 (3790)
	Oil Field Equipment	3729 (2750)	671 (900)	5423 (4000)

### DRIVETRAIN INTERFACES

Acceptable full-load engine governed speed	1900 – 2500 rpm
Minimum engine idle speed range (with transmission in Drive)	550 rpm

### MOUNTING

Direct	SAE No.1 automatic flywheel housing with flexplate drive. Cradle mount using engine flywheel housing mounting pads and transmission rear cover mounting pads with 0.625-11 inch series bolts
Remote	Side pads on transmission rear cover, plus front trunnion mount

### TORQUE CONVERTER

Type One stage, three element, polyphase.  
Includes standard integral damper which is operational in lockup.

Model	Stall Torque Ratio	Kp-Factor* at Stall
TC-580	2.89	53.4 (62.2)
TC-680	2.08	46.9 (54.6)
TC-682	1.77	37.5 (43.7)
TC-683	1.85	30.1 (35.1)

\* Kp-Factor defines torque converter capacity. Kp = the ratio of converter pump speed [rpm] divided by the square root of the pump torque [N•m (lb-ft)]

### MECHANICAL RATIOS (Gear ratios do not include torque converter multiplication)

Range	
First	4.00 : 1
Second	2.68 : 1
Third	2.01 : 1
Fourth	1.35 : 1
Fifth	1.00 : 1
Sixth	0.67 : 1
Reverse 1	-5.15 : 1
Reverse 2	-3.46 : 1

### Ratio Coverage

Forward	5.97
---------	------

### CONTROL SYSTEM

Description	Automatic electronic, manual electric, manual hydraulic
-------------	---

**OPTIONAL ENGINE-DRIVEN POWER TAKE-OFF PROVISION**

Side mount

Location	5 o'clock position, as viewed from rear	
PTO drive gear rating	Intermittent	46 tooth drive gear, 149 kW (200 hp)
	Continuous	46 tooth drive gear, 93 kW (125 hp)

Top Mount

Location	12 o'clock position, as viewed from rear	
PTO drive gear rating	Intermittent	46 tooth drive gear, 149 kW (200 hp)
	Continuous	46 tooth drive gear, 93 kW (125 hp)

**ELECTRONIC SPEEDOMETER PROVISION**

Description	LS-TTL signal, 39 pulses per output shaft revolution
Location	Output signal from transmission TCM

**OUTPUT RETARDER PROVISION (OPTION)**

Type	Integral, hydraulic	
Capacity	Torque	Power
	2034 N•m (1500 lb-ft)	447 kW (600 hp)

**SIZE**

Depth (below horizontal centerline)	511 mm (20.1 in)	
Length (direct mount) <sup>2,3</sup>	Basic	1095 mm (43.1 in)
	With Retarder	1182 mm (46.6 in)
Width	726 mm (28.6 in)	805 mm (31.7 in)
Basic model	Height	Dry Weight
	866 mm (34.1 in)	1025 kg (2260 lb)
With direct mount filters	982 mm (38.7 in)	1025 kg (2260 lb)
With top engine-driven PTO drive gear		1039 kg (2290 lb)
With park brake (12" x 5")		1052 kg (2320 lb)
With remote mount		1050 kg (2315 lb)
With retarder		1110 kg (2425 lb)

**OIL SYSTEM**

Oil type	TES 439 (see <a href="http://www.allisontransmission.com">www.allisontransmission.com</a> for approved list)
Capacity excluding external circuits	68 litres (18.0 gallons)
Main circuit oil filter	
Standard	Manifold for full-flow, remote mounted, replaceable element, integral
Optional	Direct-mount full-flow, replaceable elements (2)
Cooler circuit oil filter (optional)	Replaceable element, remote-mounted

1. PTO ratings apply to both top and side. Combined totals cannot exceed individual ratings. 2. For remote mounting, add 254–279 mm (10–11 in), depending on flange selection. 3. Length is approximate from engine/converter mounting surface to face of typical output flange.

**6600 Series**

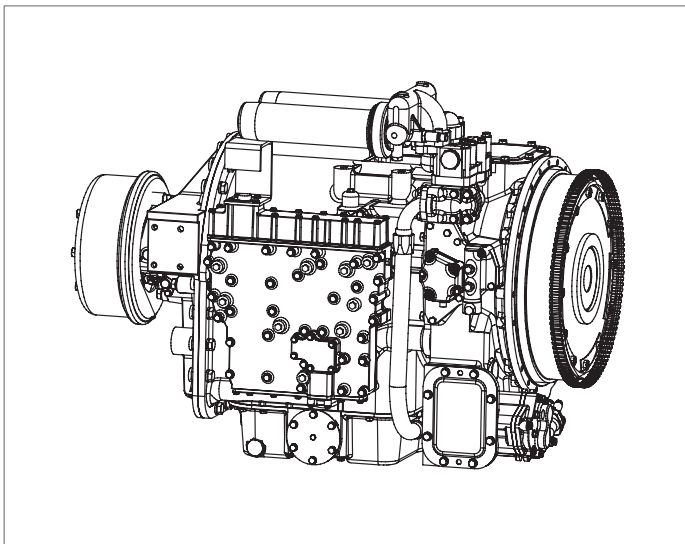

Information or specifications subject to change without notice or obligation.